

Slices of Pain: Seeing Through the Eyes of Characters in Literature Using Socio-Psychological Prism

Mercedita M. Reyes*

*University Science High School-College of Education, Central Luzon State University Science City of Muñoz,
Nueva Ecija, Philippines.*

ABSTRACT

Anchored on the field theory of Kurt Lewin and functionalism of Emile Durkheim, this study brought to the fore some slices of pain as reflected in six select novels from Asia and Africa. This literary investigation owes its magnitude and significance in appreciating literature through the prism of the sciences - psychology and sociology. The study attempted to describe characters in terms of their environment and their psychological needs, identified slices of pain that confronted them and evaluated how select influences affected them. The researcher made use of the descriptive-analytical research design to explicate qualitative data from the select novels. The study produced psychological fields of major characters in the novels. How the characters deal with pain was influenced by the multitude of processes in their physical or social world as indicated by the boundary zones of their life spaces, their cognitive structure, their ways of perceiving and some processes outside themselves. The major characters were located between the positive and negative forces which were mutually exclusive. The life spaces of the individuals were influenced by the state of their needs and the effects depended on the intensity of that need and on the fluidity of the related areas of the life space. The social aspect was explained by its reflective causes in the context of social solidarity, social integration, social phenomenon, social cohesion, and their various forms. Field theory in psychology, functionalism in sociology and their underpinnings could well be incorporated in the study of literature.

Keywords: Literature, Social Psychology, Field Theory, Functionalism.

1. INTRODUCTION

The constructive nature of social knowledge and literary texts, as creations of time, affected by and with effects of the environment, could create 'possible worlds'. Literary texts in this case, may be studied according to the methods and procedures typically employed in socio-psychological research.

Pressing forth our search to understand ourselves, the sciences have introduced us to social psychologists – the authors of literary texts. Because of their mastery and competence in treating psychosocial phenomena, authors emerge as bearers of a type of knowledge different from that of the scientist and that of the 'practical' person, busy getting on with everyday life.

Psychologists appreciate this ability and often refer to the richness and depths shown by poets and writers considering the psychic and relational aspects of life, or the familiarity with which they approach such extreme themes as hatred, love, death, suffering and pain.

The complex nature of humanity and its equivalent simplicity are oftentimes understated. With the available choices and possibilities, we create and choose our situations in life. Inner

*E-mail: merceditareyes@clsu.edu.ph

attitudes, predicaments, moods, and needs to name a few, affect how we live, how we appreciate happiness, or how we endure suffering at the downside.

Adjusting the elements of social environment, psychological experience would ensue. In turn, the person's psychological state influences the social field or milieu in a bigger and more scientific perspective.

Understanding people's plight affects how we view others and how others view us. It makes us realize that there have been sharp slices of pain that people have to go through in order to survive, although at times up to the end pain has been triumphant, an overpowering experience that makes people whimper and wallow in grief, simply because the slices of pain have been so sharp, so strong to deal with.

Kurt Lewin revolutionizes thought by empirically showing that human behavior is not only a product of one's internal make up but is also greatly affected by the dynamic environment in which an individual lives. At a macro level, Emile Durkheim theorizes on functionalism. He views the self being integrated in a social web and thus historical relations greatly influence actions.

Fusing these related injunctions, this study articulated the pains of characters in six select novels. With countries bearing colonial past, traces of which were embedded in their fiction, novels from Asia and Africa gave flesh to the life spaces of characters whose lives were subjected to extreme trial and whose paths were marked with painful experiences, hence leaving indelible share of ink in literary investigation.

2. OBJECTIVES

This study brought to the fore the slices of pain of individual characters in select Asian and African novels.

Specifically, the study had the following objectives:

- i. describe characters in terms of their:
 - a. environment,
 - b. psychological needs;
- ii. identify slices of pain that confront individual characters; and
- iii. determine how social influences affect the individual characters.

3. METHODS

3.1 Subject

The study covered six select novels - three from Asia and three from Africa. The novels include: *A Question of Power* by *Bessie Head*, *No Harvest but A Thorn* by *Shannon Ahmad*, *Ermita* by *F. Sionil Jose*, *The Great Ponds* by *Elechi Amadi*, *No Longer at Ease* by *Chinua Achebe* and *The God of Small Things* by *S. Arundhati Roy*. These novels were determined from a set of criteria.

3.2 Data Collection

The study went through four phases: Phase I: Survey, Reading and Initial Listing of Novels; Phase II: Preparation of Criteria for Final Selection of Novels; Phase III: Rereading and Final Selection of Novels; and Phase IV: Applying Lewin's Field Theory and Durkheim's Functionalism.

3.3 Analysis

Systematically, the novels went through these stages for analysis:

- a. producing the psychological fields of characters;
- b. identifying slices of pain that confronted individual characters; and
- c. evaluating the impact of social influences to the individual characters.

4. RESULTS AND DISCUSSION

The study produced these psychological fields:

i. *A Question of Power* by Bessie Head

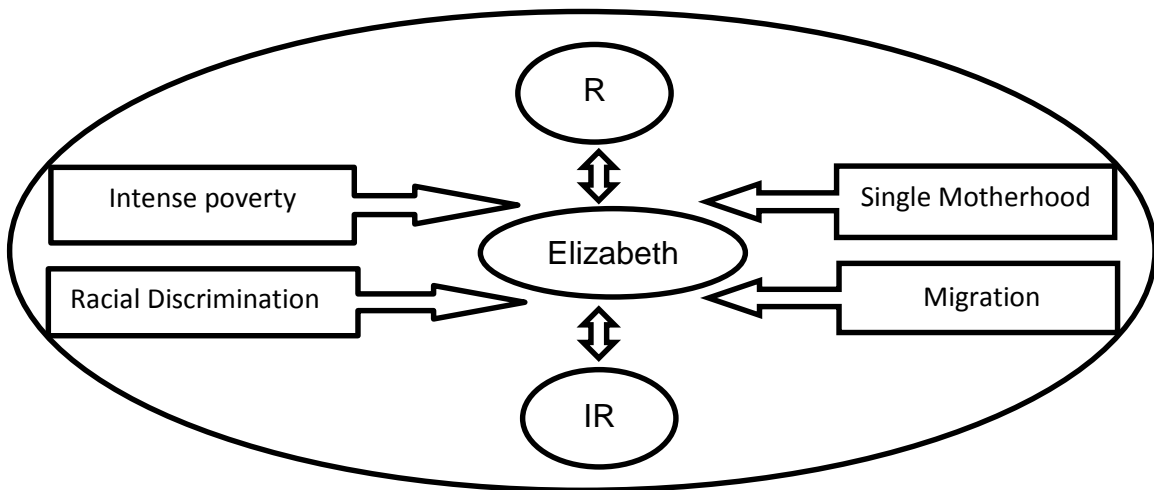

Figure 1. The psychological field of Elizabeth in *A Question of Power*.

ii. *No Harvest but A Thorn* by Shannon Ahmad

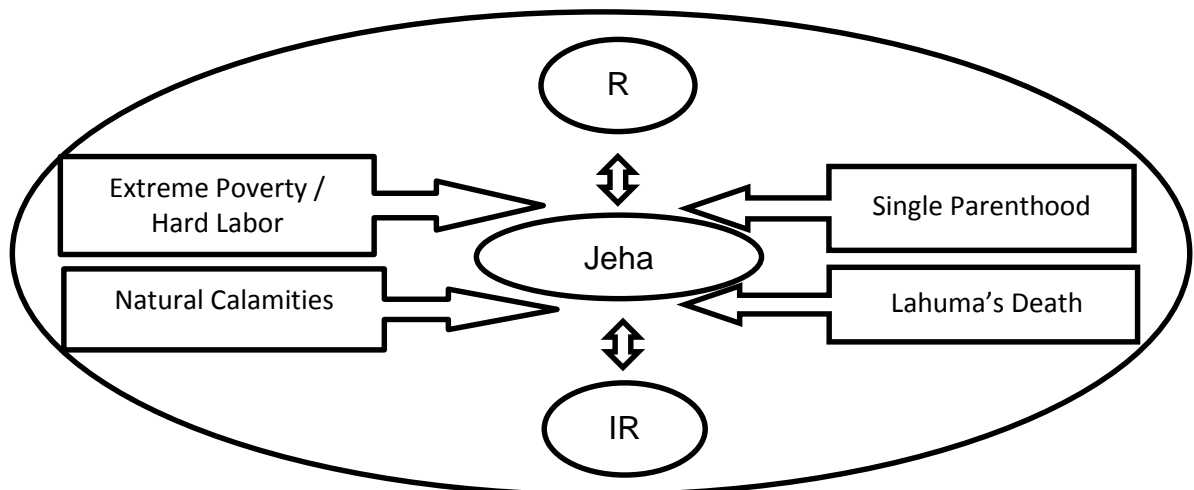

Figure 2. The psychological field of Jeha in *No Harvest but A Thorn*.

iii. **Ermita** by *F. Sionil Jose*

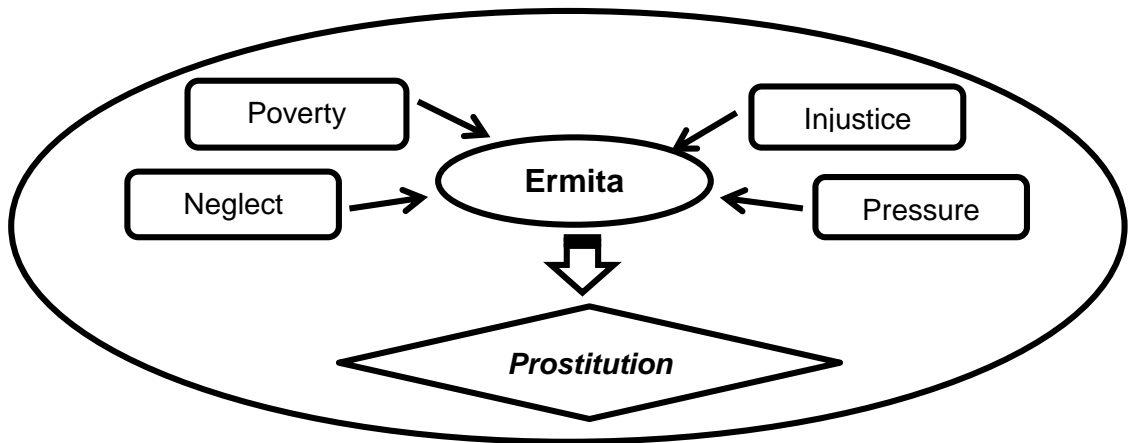

Figure 3. The psychological field of Maria Ermita in *Ermita*.

iv. **The Great Ponds** by *Elechi Amadi*

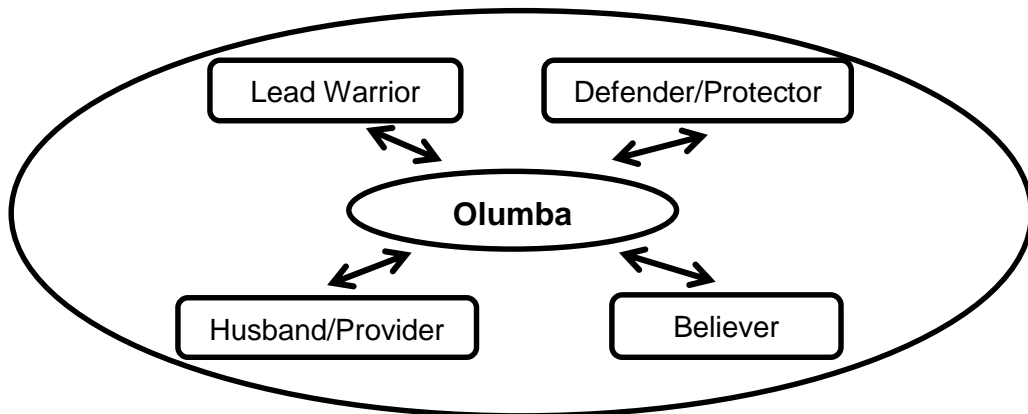

Figure 4. The psychological field of Olumba in *The Great Ponds*.

v. **No Longer at Ease** by *Chinua Achebe*

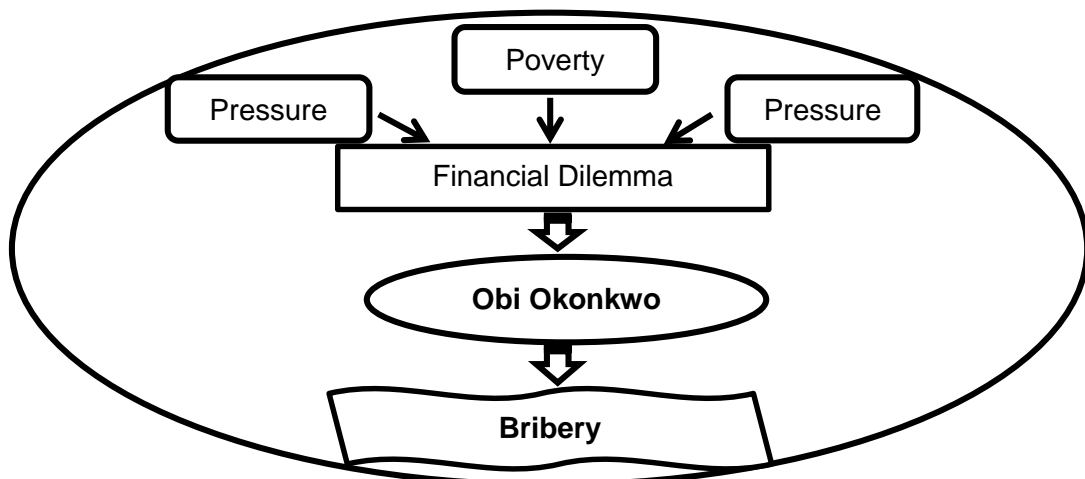

Figure 5. The psychological field of Obi Okonkwo in *No Longer at Ease*.

vi. **The God of Small Things** by *S. Arundhati Roy*

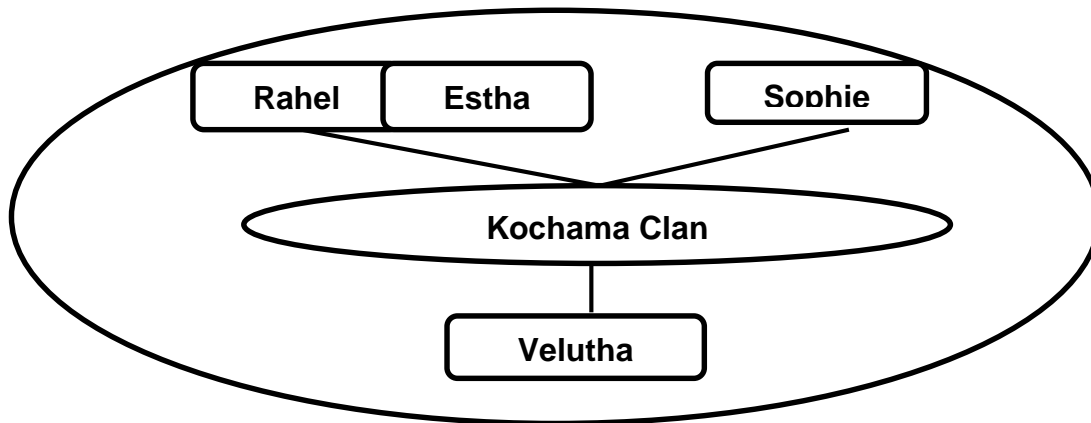

Figure 6. The psychological field of Rahel, Estha and Sophie Mol in *The God of Small Things*.

How the characters deal with pain was influenced by the multitude of processes in their physical or social world as indicated by the boundary zones of their life spaces, their cognitive structure, their ways of perceiving and some processes outside themselves.

The major characters were located between the positive and negative forces which were mutually exclusive – opposite in directions and about equal in strength, causing torture, pressure, frustration, and to some degree distress to the extreme. The life spaces of the individuals were influenced by the state of their needs and the effects depended on the intensity of that need and on the fluidity of the related areas of the life space.

Applying functionalism, the study deduced the following:

i. **A Question of Power** by *Bessie Head*

The fundamental rule is to consider social facts as things. Elizabeth, the major character in this novel, as an individual could not live without developing ideas about her society, according to which she produced her behavior. Her deviance or conformity as against the standard of her society was dependent on how people perceived her. Her difference or likeness determined her position - inside or outside that society.

No surprise that as Elizabeth learned to live with the village people, she began to embrace such social ethos, making her part of their pains and of their glory. With exchange of greetings every day, she became attached to the neighbors. There existed social solidarity from the division of labor – thus division of pains too, making them more endurable.

Highly exemplified in the novel, the villagers stripped off their individuality for the group. Motabeng village is a community of people with divergent aspirations.

Racially entrapped, Elizabeth was neither black nor white. She was represented without definite race, but because she adapted the ways of Motabeng people, she became one of them and so the society had imposed upon her its ways of acting and thinking, that dictated normality.

She was believed to have regained sanity because the society believed so. She was normal in that she had become one of them. She was like some others in the village.

ii. **No Harvest but a Thorn** by *Shannon Ahmad*

In this novel, the religious undertone was carefully borne at the backdrop of its masterful depiction of the hardships of a farming family, and the struggle of the peasants and their belief in an Almighty God. The novel is an exposition of a peasant struggle, a repugnant celebration of the rural Malay livelihood and its associated downsides.

The death of Lahuma, the father character in the novel, gave the village something to talk about during wee hours – that of dying miserably because of sin. Jeha could not accept the neighbor's whispers, but Lahuma was dead. She found herself imprisoned in a makeshift cage, well contained of her pain.

The village as a whole was subject to calamities like floods, attacking birds, the *tiaks*, infestations of crabs, the thorns, and the snakes. The peasantry was also constrained by the limited agricultural land upon which greater pressure was exerted. Hints of social stratifications could be traced on the disparity magnified by the tractors and machines, by the length and shortness of labor required to accomplish fieldwork, the life lived by Lahuma and the rest of the villagers and that of the Tok Penghulu, the chief, and his family.

In the novel, community people lived their lives accustomed to rituals and ceremonies that were primitive, but socially viewed as relevant to the times. When Lahuma's body swelled, rituals were observed, believing that in the hands of Allah, he would be restored back to health. Ahmad's characters did not once question God's wisdom and purpose, they did not cease in their toil. Ahmad presented a model "peasant" responding to circumstances of great hardship and suffering.

iii. **Ermita** by *F. Sionil Jose*

Durkheim (1985) averred that facts can exist without serving any purpose, either because they have no vital end, or because having once been useful, they lost all usefulness but continue to exist by force of habit. This was how prostitution was viewed in the novel. It was taken as a social phenomenon, a social fact that carried in itself the completeness to thrive in a well-defined society.

The history and account of the Philippines, urban and rural, primitive and modern, in all ages, and perhaps in its full cycle carried with them the dark, bitter-sweet cause-effect of equally dark, bitter-sweet prostitution.

Left with imprints of the sexual trade, this was undoubtedly a social phenomenon throughout society, but which assumed diverse forms according to locality, orientation, religious bearings, tradition and culture and such. The painful undertones were recorded differently in many shades and colors.

The issue of prostitution in this novel was tied up with extreme hardship, with poverty, with the need to survive, to feed the family and loved ones, of timeless battle to thrive and live. Clearly encapsulated in the novel was the satirical vanity of health, social status, reputation and good behavior to reveal that each was for sale to the highest bidder, if the price was right. The pains that went with it had corresponding price.

iv. **The Great Ponds** by *Elechi Amadi*

The social relations of human beings were based on logical relations. People were divided into clans. In this novel, the people belonged to the Erekwí clan, which was divided into villages from which Chiolu and Aliakoro were but two.

Traditions, practices, beliefs, rituals and ceremonies classified people. Religious practices and beliefs further categorized mankind in society. In the novel, each village had its own god, its own *dibia*, who was consulted for supernatural occurrence.

It was in spiritual way that social pressure exercised itself. No surprise then that they would rather lose their lives than dishonor the tribe. Olumba and his men of Chiolu, Wago and the fighters of Aliakoro, the chiefs and elders of the villages – all proud men were ready to submit themselves for greater good, for greater glory.

v. **No Longer at Ease** by *Chinua Achebe*

Civilization has so much to do with people's way of life. Obi Okonkwo, the lead character in the novel although intellectually gifted, came from a minority. He was mindful of survival, hence more susceptible to pain.

As the novel opened, Achebe opened the space to wonder why one such promising life (that of educated Obi Okonkwo) ended up in poor slate - poor choices, lowly convictions.

Obi Okonkwo, apparently moving, dramatically fought for love and passion. He moved against all odds, opposite of the currents. Albeit his mother's dreadful wish of harm against herself, his father's revelation of a long kept family history, his siblings' quiet yet obvious appeal for consideration, Obi stood his ground. He was an Okonkwo after all. Had it been a more strategic move for the mother, indirect contempt from the father, reverse tactic for the siblings, it could have been a different story.

Achebe's **No Longer At Ease** enlightened us on the power of our motives and feelings to go against our consciousness. This way, we could approach the matter remarkably different, we could see pain differently so that when new and fresh perspective sprout, we could embrace them without hesitation. Like Obi Okonkwo and the rest, pain must be experienced at a reasonable cause.

vi. **The God of Small Things** by *S. Arundhati Roy*

The society in **God of Small Things** mirrored a spirit, the cohesion that binds people. Not only did locals patronize their own because of familiarity but because they were connected in spirit. Its needs were their needs; they were dependent on its persistence and prosperity. Paradise Pickles and Preserves, the Kochamma family factory in this novel, depicted a condition of its own cohesion.

Conversely, society depended on what they have to offer on the basis of their shared basic characteristics. When something wrong was committed, equivalent action ensued. To both young and old alike, punishment was given relative value. Punishment existed because there was crime. Pain became a consequence - Estha's offence against Ammu, the Orange Man's lewdness against Rahel, Mamachi's consent of Chako's affairs against married women.

Punishment consisted of an emotional reaction. Arundhati Roy capitalized on this when Rahel simplified her understanding of the situation; she decided to skip dinner as her punishment for saying something harsh against her mother, Ammu.

The guilty person suffered in proportion to the wrongdoing. Velutha's disappearance and eventual death appeared to be punishment of a certain crime, for he had violated certain laws-laws of society, of polarity between the touchable and untouchable.

Logically, the God of small things recognized the existence of pain along with positive counterparts in the issue of existence, irrespective of age, color, gender, race, affluence and magnitude of authority.

5. SUGGESTION

The following are offered as suggestions based on the study findings:

- i. Considering the wealth of Kurt Lewin's field theory and of Durkheim's functionalism, the incorporation of their essential underpinnings in the study of literature is highly suggested.
- ii. Asia and Africa are rich continents in terms of history and literature. Many other aspects in human life can be explored in these two divergent continents.
- iii. Other novels from emerging countries or from war-torn countries could be subjected to the same analysis.
- iv. This socio-psychological perspective could also be employed for the reading and rereading of classical novels. The literary pieces that best go with the analysis using these theories/propositions are those that portray characters with extreme trial or suffering.

REFERENCES

- Achebe, Chinua. (1960). *No Longer at Ease*. Fawcett Premier Book. Connecticut, USA.
- Ahmad, Shahnon. (1972). *No Harvest but a Thorn*. Oxford University Press. Malaysia.
- Amadi, Elechi. (1969). *The Great Ponds*. Cox Wyman Ltd, Reading Berkshire. Great Britain.
- Blumer, Herbert. (1966). *Sociological Implications of Mead*. American Journal of Sociology
- C. W. Morris. (1934). *Mind, Self, Society*, University of Chicago.
- Fagan, E. R. (1964). *A Process for Teaching Literature*. The Pennsylvania State Press.
- Head, Bessie. (1974). *A Question of Power*. Heinemann Educational Books Ltd. London
- Jose, F. S. (1988). *Ermita*. Solidaridad Publishing House. Manila Philippines.
- Kelly, H. H. (1973). *The Process of Causal Attribution*. American Psychologist
- Lewin, Kurt. (1964). *Field Theory in Social Science*. Harper and Brothers.
- Lewin, Kurt. (1951). *Principles of Topological Psychology*. Iowa
- Marrow, A. J. (1969). *The Practical Theorist: The Life and Work of Lewin*, New York: Basic books.
- MacCaghy, C. H. et al. (2008). *Deviant Behavior*. 7th Ed. Pearsons Education, Inc. USA. Microsoft Corporation.
- Mead, G. H. *The Social Self*. Journal of Philosophy, Psychology, Scientific Methods.
- Millett. F. B. (1950). *Reading Fiction: A Method of Analysis with Selections for Study*. New York: Harper and Brothers Publishing.
- M. H. Moore. (1936). *Movements of Thought in the Nineteenth Century*, University of Chicago.
- Myers, David. (2008). *Social Psychology*. McGraw-Hill, Inc. USA.
- Nichols, S. G. (1962). *Introduction for Concepts of Criticism by Welleck*. New Haven and London: Yale University Press.
- Rousseau, R. L. (1999). "The Quest for Happiness" Psychology Today.

- Roy, Arundhati. (1997). *The God of Small Things*. New Haven and London: Yale University Press.
- Shepherdson, Charles. (2000). *Vital Signs: Nature, Culture, Psychoanalysis*. New York: Routledge.
- Norman, et al. *Psychology: Understanding Ourselves and others*. American Book Company.
- Thompson, et al. (1985). *Reading from Emile Durkheim*. New York: Routledge
- Wellek, Rene. (1963). *Concepts of Criticism*. New Haven and London: Yale University Press.
- Wheelan, et al. (1985). *Advances in Field Theory*. Harper and Brothers.

