

# COVID-19 Home Monitoring using GPS with Geographic Prohibitions

Muhamad Asyraf Mahadzir<sup>1</sup>, and Saidatul Norlyana Azemi<sup>1,2</sup>

<sup>1</sup>Advanced Communication Engineering, Centre of Excellence (CoE), Universiti Malaysia Perlis (UniMAP), Perlis, Malaysia

<sup>2</sup>Electronic Engineering Technology, Universiti Malaysia Perlis (UniMAP), Perlis, Malaysia.

Corresponding author: s191020957@studentmail.unimap.edu.my.

**ABSTRACT** Last month, Health Minister Adham Baba introduced a new strategy, allowing Covid-19 patients with mild or no symptoms to recuperate at home. Additionally, individuals serving as caregivers and those in close contact with someone who has COVID-19 were advised to stay home as well. However, with a substantial number of people undergoing home quarantine, monitoring their compliance became challenging for the authorities. To address this issue, a proposed GPS monitoring system is suggested to automatically identify the geographical location of individuals under surveillance (PUS). The system tracks PUS through a receiver system, ensuring they remain within the designated quarantine area. Any movement beyond this designated area triggers a warning, immediately notifying the authorities for necessary action. Specifically, the device generates an alert on the user's system and sends the GPS coordinates of the PUS to the authorized contact number via SMS. This in-situ information enables prompt tracking of any escaped PUS, facilitating quick response and intervention..

**KEYWORDS** Street light , wireless control system, wireless communications.

## I. INTRODUCTION

Street lighting is the most basic thing needed for a public road. Thus, installing these systems is very crucial for every public road user. This system helps road users when night comes. Nowadays, a lot of streetlights have been installed and are embedded with a timer to help determine night hours [1-2]. An average time for a streetlight to be turned on is about 12 hours and that is between 7 pm to 7 am. That is during the night but what happens when there are times that dark came during the daytime because the sun is blocked by the clouds and the apparent cause for this event is thunderstorms or just heavy rain. The solution for this problem is just by installing a photocell which is a light-sensitive sensor that responds to the amount of light detected [3-5]. When the light level is too low, such as at dusk or when the sky is heavily overcast, the sensor informs the streetlight's computing unit to activate the supply of electricity. This system is widely employed in every nation on earth.

For this project, the urge to enhance the street light system is very high due to problems that have been encountered by technicians that are working in that area. For example, if there is a problem at a certain area of streetlight, the technician would have to physically go to that problematic streetlight to check and determine whether it is a minor or major problem. Such as, a lamp has burnt, a fuse burnt or something major maybe there has been a cable stolen etc. It is obviously a tedious and hardship of technicians trying to do their work. So, an idea came to increase the system efficiency and that is by adding wireless communication to the control system. This upgrade will ease everything and can be controlled via wireless communication.

Installing smart, adjustable electronic ballasts that can automatically detect electric failures and lamp problems, measure, and transfer data on the state of the lighting, energy consumption, lighting level, current, voltage, and power factor, and receive interruption and lighting control commands are all part of this process. If there is an internet connection, this system will automatically update the data of the streetlights.

In the previous study there were 2 approaches to make energy savings on streetlamps first, replacing old streetlamps with more efficient lamps such as light-emitting diodes (LED) [6-8]. Lamp LED is a semiconductor that emits incoherent monochromatic light when given a forward voltage. These LEDs utilize the electroluminescence effect in generating light. In addition to being more power-efficient, LED also has other advantages that as a more natural color, long life and can set the light intensity (dimmer). Second, building remote streetlights monitoring and control systems to facilitate the control center to make savings and maintenance more effective [9-10].

Although the minimum acceptable or legal requirements for controlling lighting are not the same for industry, offices, streets, and public lighting, the concept is the same for all of them, a fixed lighting intensity must always be achieved with energy efficiency and the lowest possible cost for energy consumption to increase the expected lifespan of the lamps. Because of this, it is feasible to generate high-quality energy in a manner that is both more effective and lucrative by making use of the lamps, ballasts, and control systems that are currently on the market, in addition to the methods that are necessary to develop an efficient lighting system [11-12]

The traditional methods of conserving energy involve turning off streetlights entirely or in part. However, this results in less uniform lighting and has a significant negative effect on the number of time lamps are able to remain in use. Currently, the wireless communication technology that has been applied to the street light control system is ZigBee [13-14]. Zigbee is an IEEE 802.15.4-based communications radio designed to be low-powered and has low data rates for personal networking. Unfortunately, the price of ZigBee on the market is more expensive than wireless communication radios like radio frequency and Wi-Fi [15-16]. Hence this will design and develop the smart street light system and show the efficiency of this system compared to the traditional system.

## II. STREETLIGHT CONTROL SYSTEM DEVELOPMENT

The project's main purpose is to save energy by only turning on streetlights when they are needed. This project shows a streetlight prototype with two IR sensors, two lamps, one 5V relay, three LDR sensors, one RF module, and all connected to one microcontroller which is Arduino Nano. All of these components are being duplicated for another set which is for Lamp1 ID2 and Lamp2 ID2. The RF module's purpose is to update the LDR sensor's data on whether the lamp is well functioning or fails to turn on. The message sent by the RF module will display in the RF Module Manager at the PC terminal. The steps to implement in this project are outlined below in Figure 1.

Figure 2 shows the block diagram for this project. The LDR sensor and IR sensor as the input of this system are connected to the microcontroller which is Arduino Nano. LDR sensor will detect the presence of light and the intensity of light while the IR sensor will detect the presence of any motion and movement. This system will use 3 LDR sensors, one of them will detect the absence of light while the others function when the lamp produces. The RF module's transmitter is connected to the receiver of the microcontroller and the transmitter of the microcontroller is connected to the RF module's receiver.

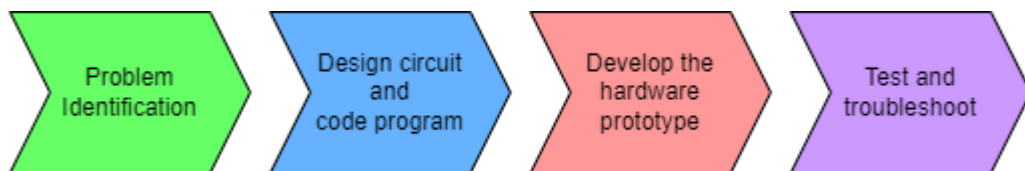

Figure 1: Implement step of the project

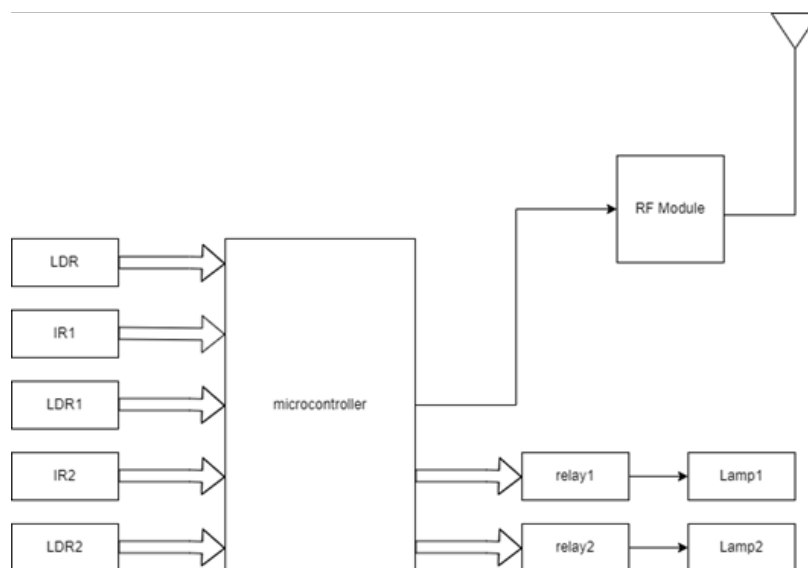

Figure 2: Block Diagram

During the absence of light which satisfied the condition to trigger the main LDR while there is a movement that occurred around IR1, the microcontroller will receive information. After that, the power

relay module that is operated by an electromagnet is activated by a separated low-power signal from the microcontroller. When activated, the electromagnet pulls to normally open an electrical circuit in lamp 1 which will switch on the lamp.

Next, LDR1 will be triggered with the presence of light that is produced by lamp 1 which will be resulting the microcontroller informing the RF module about conditions that have been satisfied. The same process will occur to IR2 when there is a movement detected by the sensor. The RF module that is connected to the microcontroller will forward the data by sending messages to the RF module that is linked to the PC. If the LDR1 sensor or LDR2 sensor detects the presence of light that produces by lamp 1 or lamp 2, the PC terminal will display lamp 1 or lamp 2 “OK” otherwise it will display lamp 1 or lamp 2 “FAIL”.

As shown in the Figure 3 , the main components of this circuit are the ArduinoNano, LDR sensor module, IR sensors module, Low Power with Long Range RF Module, and AC bulbs. This project makes use of two types of power supplies, AC and DC. The bulbs were powered by the AC supply, while the Arduino Nano, RF Module, and relay module were powered by the DC supply. The LDR sensor module is utilized to identify whether it is day or night in this application. Because it generates variable resistance based on the amount of light received, the LDR sensor module must be connected like a potentiometer. All of the Vcc for the LDR sensor module and the IR sensor module is connected to the 3.3V pin on the Arduino Nano, while the Digital Output (DO) for each sensor module is connected to its respective pin, which is IR2 to D2, LDR2 to D3, IR1 to D4, LDR1 to D5, and the main LDR to D6. The relay is connected to the Arduino Nano's IN1 to D7 and IN2 to D8 as shown in the circuit design. Lamp1 is connected at Normally Open 1 (NO1) and Common Contact 1 (COM1). The same goes for Lamp2, which is connected to Normally Open 2 (NO2) and Common Contact 2 (COM2).

The Low Power with Long Range RF Module is then linked to the Arduino Nano. The STB, STA, and GND pins are connected to the Arduino Nano's GND terminal. Meanwhile, the TX and RX pins are connected to the RX and TX pins on the Arduino Nano. Lastly, the DC power supply (5V,2A) is connected to the voltage regulator and distributed to the RF Module's Vcc. Figure 4 depicts the breadboard component connections as specified in the program. This is the connection made before the circuit is soldered on the Printed Circuit Board (PCB) to avoid loose circuits, which can lead to disconnection and errors.

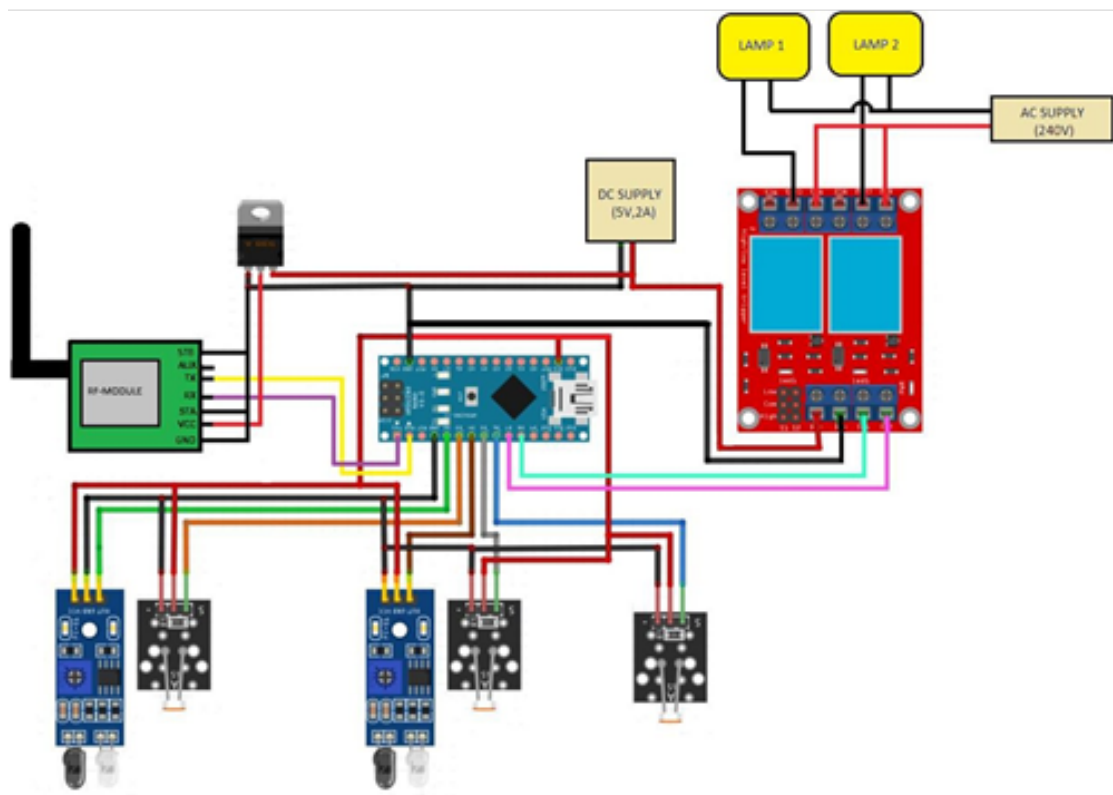

Figure 3: Circuit Diagram

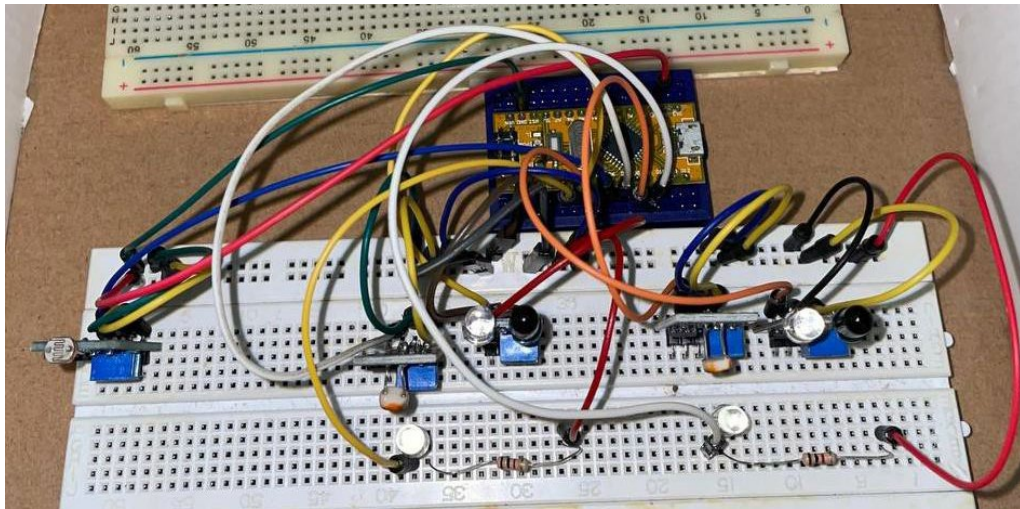

Figure 4: Full circuit connection on breadboard for prototyping testing.

### III. RESULT AND DISCUSSION

In this chapter, result and the discussion of the Streetlight Control System Based on Wireless Communication is presented. This system will begin when the microcontroller received information if there is no light, which satisfied the condition to trigger the main LDR, and there is movement around IR1. This system will be implemented in the smart city area. This program will continuously be running day and night as the system depends on the sensor detection and surrounding.

The project development consists of a few steps. Firstly, LED blinking coding is generated. Then, the circuit connection for the sensor is paired with a microcontroller to test whether the LED has a blinking function. After that, another LED is added to the connection and new coding is generated to link both LED in the same microcontroller. The prototype is reinspected to identify the functionality before any connection with the RF Module occurred. Shown in Figure 4.1 is the coding for LED blinking.

```
ledblink
int LED1 =2 ;
int LED2 =3 ;

void setup() {
  pinMode(LED1, OUTPUT);
  pinMode (LED2, OUTPUT);
}

void loop() {
  digitalWrite (LED1, HIGH);
  digitalWrite (LED2, LOW);
  delay (1000);

  digitalWrite (LED1, LOW);
  digitalWrite (LED2, HIGH);
  delay (1000);
}
```

Figure 5: LED blinking coding.



Figure 5 shows the coding for LED blinking. The first row is the declaration of the output which is LED1 and LED2 that is connected to pin D2 and D3 respectively at microcontroller. The blinking of the LED will take place at one second as set in the program. Figure 6 shows the LED1 as Lamp1 is functioning well. The LED will turn on during the deficiency of light which satisfied the condition to trigger the main LDR while there is a movement that occurred around IR1. In the circuit, the LED1 is connected to pin D2 at the Arduino Nano as declared in the program. Figure 7 shows LED1 connected to D2 of Arduino Nano and LED2 connected to pin D3 of Arduino Nano, both LEDs turn ON when the main LDR detects the surrounding is dark and the IR1 and IR2 sensor detect the presence of an object. The LED will only turn on for 10 seconds, the timer will start counting once the IR sensor detects an object. The timer can be set, and it is not fix to only 10 seconds. Users have flexibility to set the timer accordingly. Figure 8 shows that LED1 remains ON and LED2 is turning OFF. This is because the IR1 sensor detects obstacles for the second time after the detection of the IR2 sensor. LED2 turns on for 10 seconds while LED1 remains on for 20 seconds. The same approach will take place each time the IR sensor detects any movement.

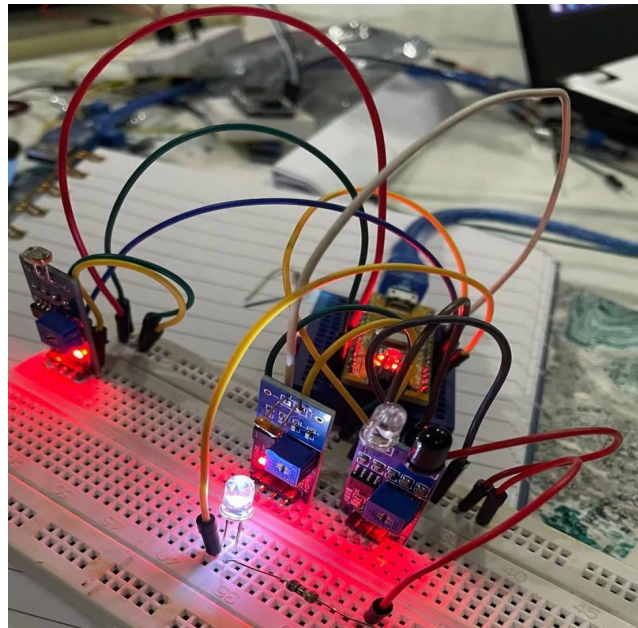

Figure 6: LED1 turn ON

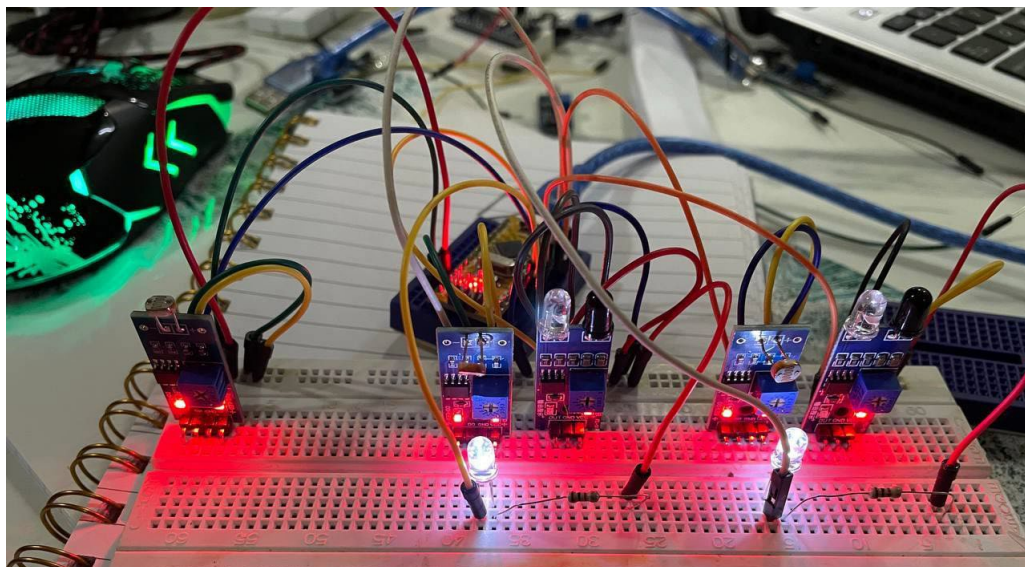

Figure 7: LED1 and LED2 turn ON

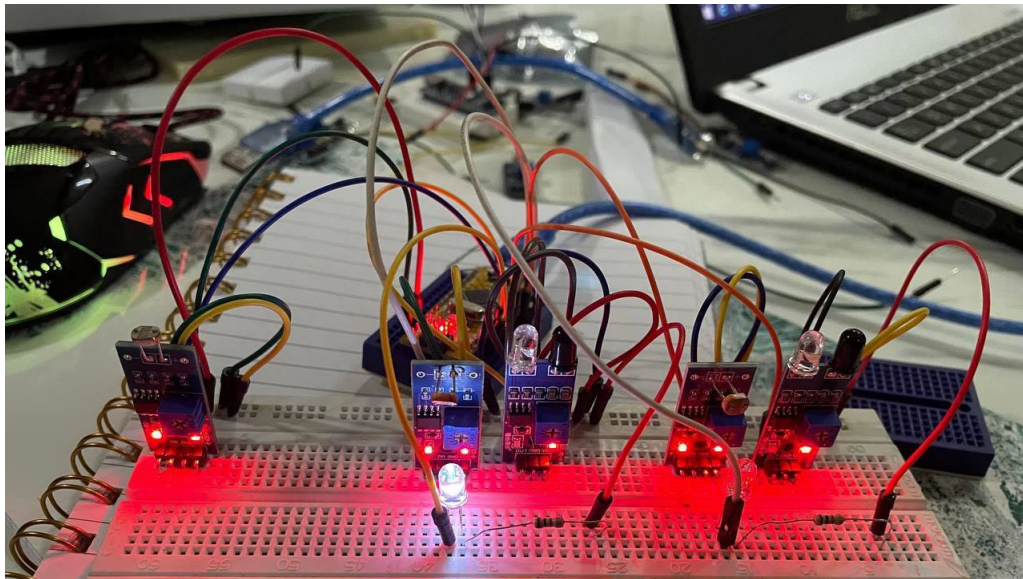

Figure 8: LED2 turns OFF and LED1 remains ON

This section will be highlighting the changes of LED to 230V light bulbs declared as Lamp1 and Lamp2. A relay is required to connect the bulb to the circuit. The connections for the relay are uncomplicated. A wire is cut from a light bulb, and it separated into two wires. Then connect one wire to the relay's NO (normally open) pin and the other wire to the relay's COM (common) pin. This relay has been used to control the appliance of command from the sensor. Simultaneously, the relay acts as a converter, increasing the voltage from low to high. The use of bulbs rather than LEDs is since streetlights have a high voltage, making LEDs impractical for use as a prototype. The operation that occurred to the lamp is the same as the process that has been performed on the LED which is successfully testified. The microcontroller will send a signal to the relay, which will activate the relay and turn on the lamps. The signal is generated by a sensor that detects passed by vehicles in the dark surrounding. The connection between the relay and the bulbs that are declared as Lamp1 and Lamp2 is illustrated in Figure 9. The circuit is connected to the relay via its four corresponding pins. Lamp1 is wired to both the Normally Open 1 (NO1) and the Common Contact 1 terminals (COM1). The same is true for Lamp2, which is linked to Common Contact 2 (COM2) and Normally Open 2 (NO2).

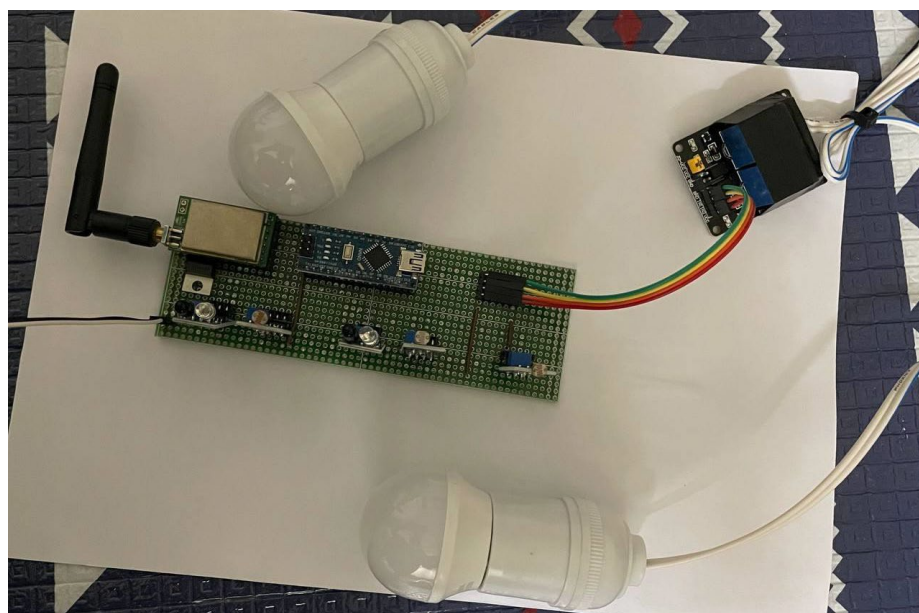

Figure 9: Connection of Relay and Bulbs



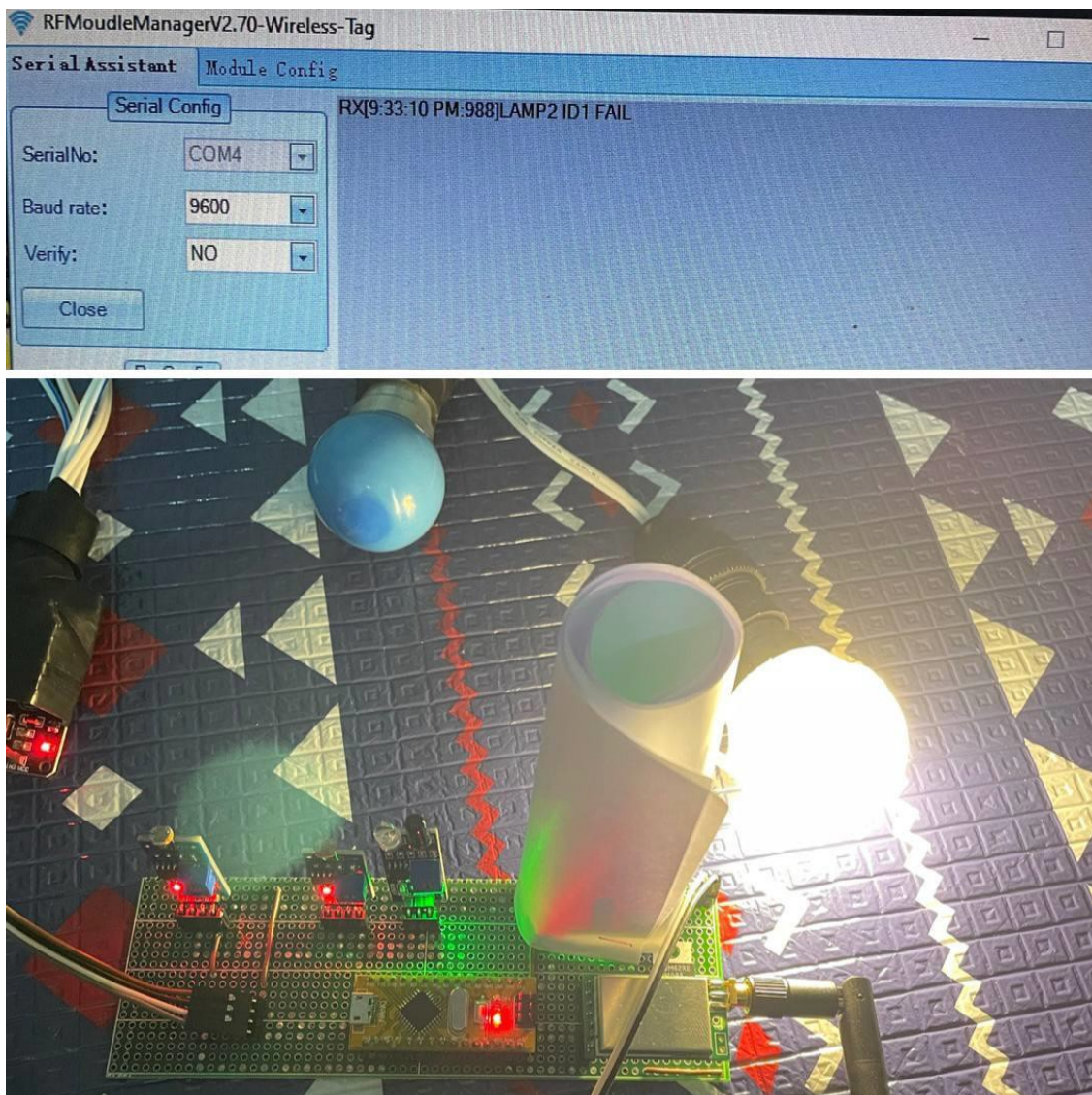

Figure 10: Lamp2 ID1 fails to detect the presence of light

As shown in Figure 10, Lamp2 is activated whenever the physical surroundings are dark and the IR2 sensor module detects the presence of an obstruction. On the other hand, the result that is displayed at RF Module Manager is "Lamp2 ID1 FAIL" since the LDR2 was unable to detect the presence of light produced by Lamp2. The information presented in Figure 11 demonstrates that all lamps, with the exception of Lamp2 ID2, are operating as expected. Even though it was a dark environment, the IR2 sensor module on the microcontroller ID2 was unable to detect any kind of obstruction. As a result, the Lamp2 ID2 did not turn on.

The RF Module is utilized in this system to transfer and receive data from streetlights. The objective of the RF module is to update the LDR sensor's data on whether the lamp is operating properly or not. The RF Module process begins when a car passes by on the street and is sensed by the IR sensor, which reacts to the darkness by triggering the main LDR sensor. The LDR1 sensor detects the presence of light emitted by the Lamp1 and the sensor transmits a signal to the microcontroller, which then sends data to the RF Module. If LDR2 senses the existence of Lamp2's light, the same thing will happen.



Figure 11: Result for all lamps on microcontroller ID1 and ID2

In this system, three RF modules are used. The first module, mac-address 0000, is operated as a base module and is connected to the PC as a receiver module. Following that, the mac-address 0001 module is connected to the microcontroller defined as ID1, and the mac-address 0002 module is attached to the microcontroller declared as ID2. When the microcontroller receives a signal from LDR1 or LDR2, if Lamp1 works properly, the RF Module attached to the microcontroller will send the message "Lamp1 ID1 OK" to the base module, which is connected to the PC, as indicated in the system's code. The same message will be transmitted to the base module if LDR2 detects light from Lamp2 ID1 and another lamp from ID2, the message sent by the RF module will display at the PC terminal. However, the message of failure will appear if LDR1 and LDR2 is unable to detect the presence of light. The RF module manager displaying the results for Lamp1 and Lamp2 formicrocontroller ID1 is depicted in Figure 12. It demonstrates that both of the lamps are functioning properly.

The results for Lamp1 ID1 and Lamp2 ID1 are shown in Figure 13. Lamp1 ID1 is working properly, but Lamp2 ID1 has failed. This is attributed to the reason that LDR2 is unable to detect the existence of light from Lamp2 ID1. The result for all lamps from microcontroller ID1 and ID2 is shown in Figure 14. Microcontroller ID1 is connected to two lamps, while microcontroller ID2 is attached to the other two. All the lamps are working properly. Table 1 tabulated the overall result of the system.

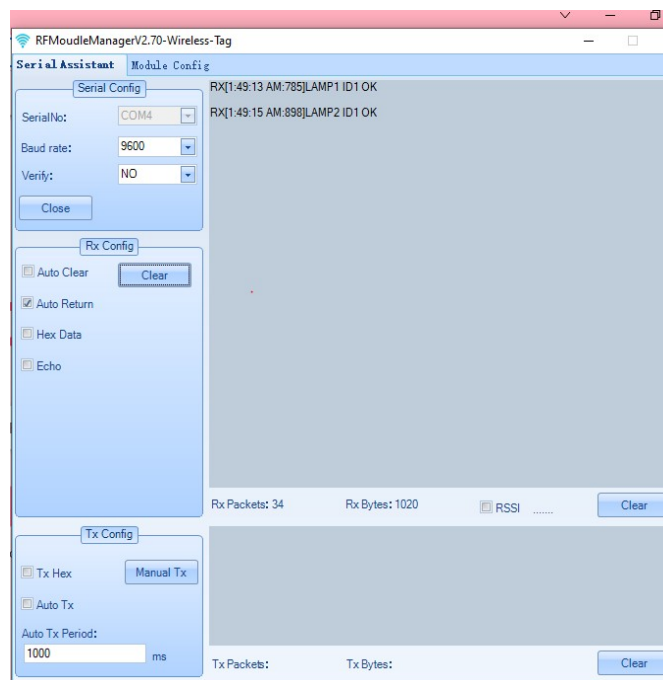

Figure 12: Results Lamp1 and Lamp2 for ID1



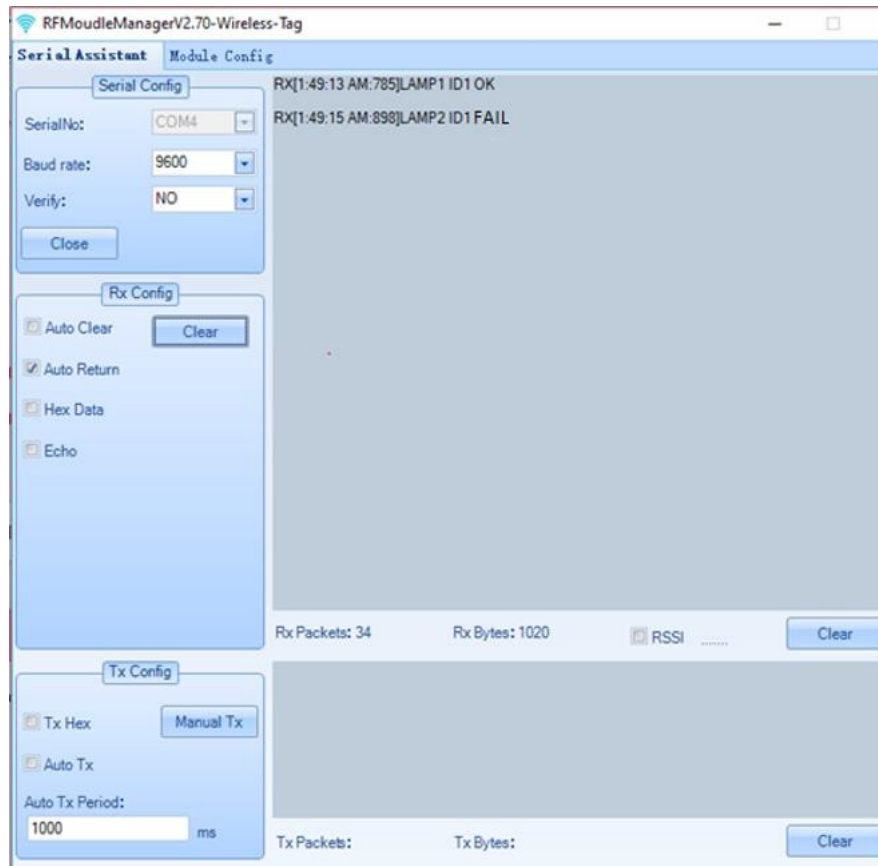

Figure 13: Result of failure

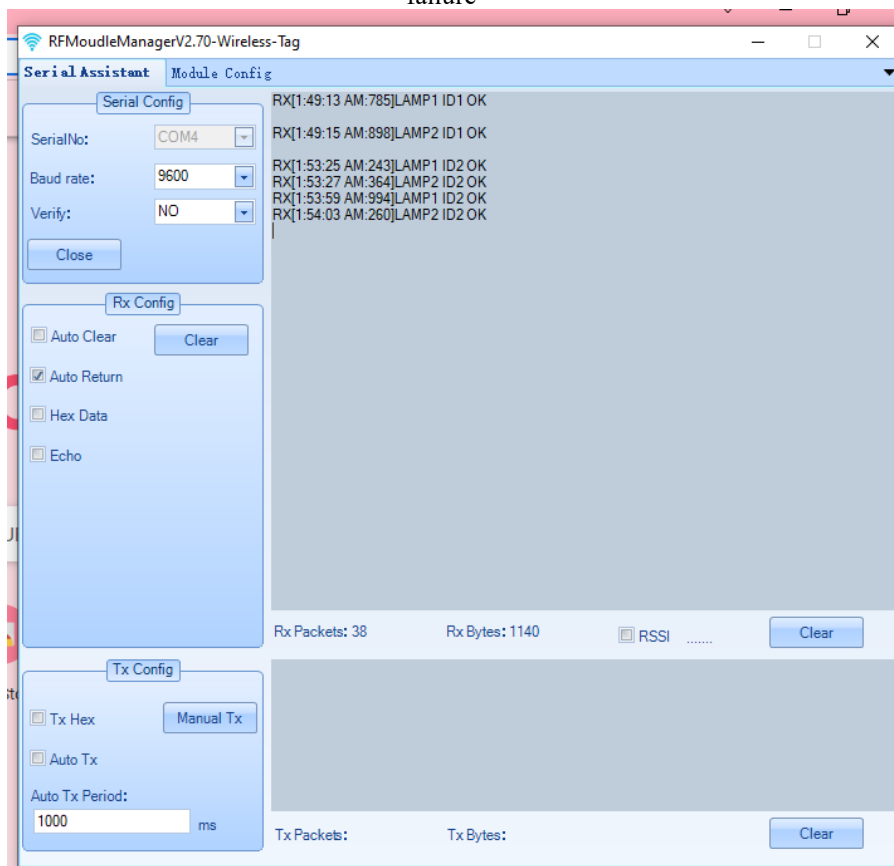

Figure 14: Result for all lamps

TABLE 1: SUMMARY OF OPERATING CIRCUIT RESULT

Streetlight	Condition of Light ON/OFF	Command	Result
Lamp1 ID1	ON	OK	All streetlight well function.
Lamp2 ID1	ON	OK	
Lamp1 ID2	ON	OK	
Lamp 2 ID2	ON	OK	
Lamp 1 ID1	ON	OK	Lamp2 ID2 fail to work.
Lamp2 ID1	ON	OK	
Lamp1 ID2	ON	OK	
Lamp2 ID2	OFF	FAIL	

## VI. CONCLUSION

In chapter 4, the prototype can function well and achieves one of the objectives which is to evaluate the efficiency of the system to ensure its ability to monitor and control the streetlight wirelessly. From the result, the developed hardware is able to transfer data from the sensor to the RF module without data transmission delay issues. According to the datasheet, the streetlight system can be monitored up to 5 kilometers away. The RF Module Manager will display data so that the user or monitor person may keep track of the data from the sensor. From that, the user is able to act swiftly in the event of a streetlight failure. If the streetlight is in good condition, all the data is already controlled wirelessly and displayed in the Rf Module Manager, eliminating the need for a technician to go directly to the streetlight to check the condition. Therefore, a lot of energy and time can be saved by using this monitoring system.

## REFERENCES

- [1]. Abdullah, A., Yusoff, S. H., Zaini, S. A., Midi, N. S., & Mohamad, S. Y. (2018, September). Smart street light using intensity controller. In 2018 7th International Conference on Computer and Communication Engineering (ICCCCE) (pp. 1-5). IEEE.
- [2]. Yusoff, Z. M., Muhammad, Z., Razi, M. M., Razali, N. F., & Hashim, M. H. C. (2020). IOT-Based smart street lighting enhances energy conservation. *Indonesian Journal of Electrical Engineering and Computer Science*, 20(1), 528.
- [3]. Suganya, S., Sinduja, R., Sowmiya, T., & Senthilkumar, S. (2014). Street light glow on detecting vehicle movement using sensor. *International journal for advance research in Engineering and technology*.
- [4]. Yoshiura, N., Fujii, Y., & Ohta, N. (2013, September). Smart street light system looking like usual street lights based on sensor networks. In 2013 13th International Symposium on Communications and Information Technologies (ISCIT) (pp. 633-637). IEEE.
- [5]. Abdullah, A., Yusoff, S. H., Zaini, S. A., Midi, N. S., & Mohamad, S. Y. (2019). Energy efficient smart street light for smart city using sensors and controller. *Bulletin of Electrical Engineering and Informatics*, 8(2), 558-568.
- [6]. Elejoste, P., Angulo, I., Perallos, A., Chertudi, A., Zuazola, I. J. G., Moreno, A., ... & Villadangos, J. (2013). An easy to deploy street light control system based on wireless communication and LED technology. *Sensors*, 13(5), 6492-6523.
- [7]. Bhairi, M. N., Kangle, S. S., Edake, M. S., Madgundi, B. S., & Bhosale, V. B. (2017, May). Design and implementation of smart solar LED street light. In 2017 International Conference on Trends in Electronics and Informatics (ICEI) (pp. 509-512). IEEE.
- [8]. Wood, J. M., Isoardi, G., Black, A., & Cowling, I. (2018). Night-time driving visibility associated with LED streetlight dimming. *Accident Analysis & Prevention*, 121, 295-300.
- [9]. Lv, Z., Hu, B., & Lv, H. (2019). Infrastructure monitoring and operation for smart cities based on IoT system. *IEEE Transactions on Industrial Informatics*, 16(3), 1957-1962.
- [10]. Satrya, G. B., Reda, H. T., Woo, K. J., Daely, P. T., Shin, S. Y., & Chae, S. (2017). IoT and public weather data based monitoring & control software development for variable color temperature LED street lights. *International Journal on Advanced Science, Engineering and Information Technology*, 7(2), 366-372.
- [11]. Muhamad, W. N. W., Zain, M. Y. M., Wahab, N., Aziz, N. H. A., & Abd Kadir, R. (2010, January). Energy efficient lighting system design for building. In 2010 International Conference on Intelligent Systems, Modelling and Simulation (pp. 282-286). IEEE.
- [12]. Pang, C., Vyatkin, V., Deng, Y., & Sorouri, M. (2013, September). Virtual smart metering in automation and simulation of energy-efficient lighting system. In 2013 IEEE 18th Conference on Emerging Technologies & Factory Automation (ETFA) (pp. 1-8). IEEE.
- [13]. Alex, R. S., & Starbell, R. N. (2014). Energy efficient intelligent street lighting system using ZIGBEE and sensors. *International Journal of Engineering and Advanced Technology (IJEAT)*, 3(4), 2249-8958.

- [14]. Vargas, C., Guamán, J., Nogales, R., & Ríos, A. (2017). Photovoltaic lighting system with intelligent control based on ZigBee and Arduino. *Energy*, 100, 190.
- [15]. Varghese, S. G., Kurian, C. P., George, V. I., John, A., Nayak, V., & Upadhyay, A. (2019). Comparative study of zigBee topologies for IoT-based lighting automation. *IET Wireless Sensor Systems*, 9(4), 201-207.
- [16]. Shahzad, G., Yang, H., Ahmad, A. W., & Lee, C. (2016). Energy-efficient intelligent street lighting system using traffic-adaptive control. *IEEE Sensors Journal*, 16(13), 5397-5405.



### BIOGRAPHIES

**Dr. Saidatul Norlyana Azemi** obtained her Ph.D in 2014 from Royal Melbourne Institute Technology (RMIT) University, Melbourne Australia. She has received the Masters of Science in Communication Engineering in 2010 from University Malaysia Perlis, Malaysia. Previously, she obtained her first degree from University Malaysia Perlis, Malaysia, with Honors, in Communication Engineering, graduating in 2007. In RMIT University Melbourne Australia, Dr. Saidatul was a winner for Poster and Oral presentation two year in a row during Higher Degree by Research Conference's day RMIT as well as School of Electrical and Computer Engineering (SECE) Postgraduate Research Day. In 2013, she received a student grant from EUMW Germany that allowed her to participate in the EUMW2013 Nuremberg Germany conference and eventually receive

Commendation for Oral Presentation. Her research interest focuses on 3-D and 2D Frequency Selective Surface, 3-D antenna structure, antenna design and diversity, dielectric materials, wireless network, and RF & microwave design. Her current H-Index is 10 (SCOPUS) and 14 (Google Scholar)



**NURHAZWANI BINTI MOHD KAMAL** is second child out of five siblings, was born in Pulau Pinang, Malaysia October 1998. She grew up in several states because of the demands of her father who worked as soldier. She is fresh graduate in Bachelor of Computer Engineering with Honours from Universiti Malaysia Perlis (UniMAP), Faculty of Electronic Engineering Technology (FTKEN).